



Version 010

INSTRUCTION FOR USE

# Dreama



Important Information: These instructions must be kept with the product at all times. This product is a prescribed Medical Device. To be used only under the guidance of a Therapist or Prescribing Practitioner. You must read these instructions carefully before use.

INSTRUCTION FOR USE

# Dreama

Note: Some fabric and plastic colours may vary,  
adjustments are not affected.



# Contents

## General Information

Safety Labels .....	7
Care & Cleaning Instructions .....	8
Maintenance .....	9
Product Induction & Hand Over .....	10
Specification & Warranty .....	11
Assembly .....	12

## Frequent Adjustments

Mattress Units .....	14
Fitting & Removing Covers .....	15

## Optional Components

Glide Lock Accessories .....	17
Locking Stop Accessories .....	18
Accessories .....	19

## Maintenance & Inspection

Maintenance & Inspection .....	25
Frequently Asked Questions .....	27
Notes .....	27



# Important Safety Info



This product must be thoroughly inspected by a qualified person at least annually



Ensure that your Therapist has confirmed that the product is correctly set up, by signing the 'Set Up' section of the Log book before using this product. If the product has not been set up by your Therapist DO NOT USE.



Jenx Limited recommends that children are never left unattended whilst using this Medical Device. Children may slip or fall when unattended and may suffer serious injury. It is the sole responsibility of the person caring for a child using this Medical Device to ensure the safety of the child in the Device should they be left alone.



Always read the instructions before operating. Failure to read and follow the Instruction for Use, especially with regard to moving parts, may pose a risk to the user.



Do not use this product if you suspect or know that it is broken or faulty. Please contact Jenx Limited immediately for advice: Jenx Limited, Tel: +44 (0)114 285 3376.



This product contains small parts which could present a choking hazard to small children.



All Jenx Limited products are tested to meet current Fire Safety regulations. Always keep products away from; naked flames, cigarettes and sources of heat such as heaters.



Jenx Limited supplies the necessary tools to adjust each product. These tools are supplied for use by trained therapists only. Store the tools in a safe place and keep away from children.



Assemble product fully before use. Please contact Jenx Limited if you have any problems at this stage. Jenx Limited, Tel: +44 (0)114 285 3376.



Ensure that good care is taken of your product: clean regularly. Do not use abrasive cleaners. When not in use, store this product in a dry place that is not subject to extreme temperatures. Places not to store this product include garages, attics or garden sheds.



All belts and harnesses should be used at all times. For therapy purposes it may be necessary to deviate from this rule and any deviation should be fully documented as part of a Risk Assessment or Therapy Program and all relevant staff and carers appropriately trained. Secure client with straps before adjusting product. Ensure finger's width between safety strap and client to prevent over tightening or client moving to inappropriate position. Adjust straps for each client and changes of clothing. Minimum Velcro® overlap: 3 inches (7.5cm) on all straps. If strap is not long enough: DO NOT USE PRODUCT.



This product conforms to the European Medical Devices Directive. It has not been tested in conjunction with other manufacturer's products. Do not add any accessories other than Jenx Limited accessories to this product. If in doubt, contact Jenx for advice +44 (0)114 285 3376.



Any changes or alterations carried out by persons other than a Jenx authorised service person will invalidate the warranty and Jenx can accept no liability for any injury or damage so caused.



All Jenx products are Medical Devices and are sold on the understanding that they will be prescribed, issued and maintained in line with current national device management guidelines.

# Key



## Key to Components



Wing knob



Allen key bolt



Swiss clip



T-Nut



Wing nut

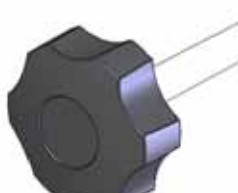

Star knob

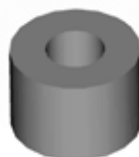

Plastic spacer



Plastic washer

## Key for Users



Carers and home users



Re-issue and stores



Professional and technical users



Scallop wheel

CHAPTER ONE

# General Information



# Safety Labels



## Serial Number/ CE Certification

The serial number is written on the CE label (see picture), which is located on the product. Please quote this number on all correspondence.

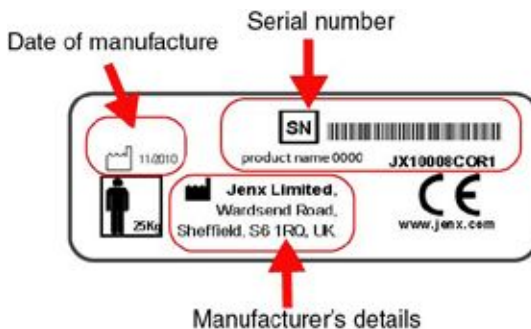

## Product Labels

Each Jenx product has a number of pictorial safety labels attached, these refer to the explanations below.



Attention/ Warning



Please read Instruction for use



Only for indoor use



Always fasten and adjust positioning straps and belts to suit the child. Adjust to suit changes in clothing. Allow one fingers width between the belt and the child



Do not leave child unattended (see page 4 for full warning)



DO NOT USE as a mobility device  
Never use product on rough ground or uneven surface

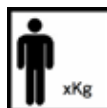

Client weight Limit (changes per model and size)



Conforms to CE Marking Regulations  
Medical Devices Directive (MDD) 93/42 EEC

# Care & Cleaning Instructions



### Fabrics, Vinyl and PU (polyurethane)

- Minor spills can be removed with a damp cloth
- Spillages should be removed as quickly as possible after contact, dab the stain, do not rub
- Do not over wet the stain
- Do not use organic solvents, dry cleaning fluids, abrasive cleaners or industrial bleaches
- Antibacterial spray or wipes can be used
- Always ensure that the product is dry before use

### Wooden Products and Parts

- For deep cleaning a low pressure steam cleaner can be used
- Do not use organic solvents to clean Jenx Products
- Soap and water or antibacterial spray can be used
- Check for breaks or splintering of the wood before re-issuing
- Daily cleaning: Spray polish or wax polish can be used

### Metal Frames and Coated Parts

- For deep cleaning a low pressure steam cleaner can be used
- Do not use organic solvents to clean Jenx products
- Soap and water or antibacterial spray can be used
- Daily cleaning: Wipe framework down with a damp cloth as necessary



# Maintenance



## Daily Checks

Daily checks of the equipment should be carried out by carers. These checks are not technical but a basic understanding of the product is needed. Multiple daily checks may be needed in schools or therapy rooms where the products are used by multiple users. The checks should include the following points:

- Replace any lost or worn washers or bolts
- Check tray for damage. Ensure that the tray edging is secure and that the tray is clean and free of any rough or sharp corners
- Check all upholstery for any signs of wear and tear
- Brush Velcro® to remove fluff
- Check wooden parts for splitting or splintering
- Check straps for fraying and missing or broken buckles
- Clean any stains or spillages
- Contact Jenx Limited if any accessories not manufactured by Jenx Limited have been attached to the product. Unauthorised accessories may affect the safety of this product and invalidate your warranty
- Check that gas spring levers are not bent. Do not use the product if any levers are bent. Contact Jenx Limited to arrange replacement

## Monthly Checks

We recommend that on a monthly basis a competent person who is familiar with this piece of equipment and who has been trained in its use should carry out a more detailed check:

- Check that all nuts and bolts are in place and secured
- Check that all mechanical movements operate fully
- Check the structure of the product for signs of fatigue
- Castors: Lift base and check each wheel to ensure it is not loose or worn. Remove any grease or dirt that has built up on the wheels, check that the brake stops the wheels rotating (where applicable)
- Check gas springs for normal operation and resistance. Slow descent (creeping) of the gas spring can be checked by observing the position of the unit over a period of time
- Check that gas spring levers are not bent. Do not use the product if any levers are bent. Contact Jenx Limited to arrange replacement

**If you have filled your product inspection log book, copies can be printed from [www.jenx.com](http://www.jenx.com)**



This product must be thoroughly inspected by a qualified person at least annually

# Product Induction & Hand Over



This product is a Prescribed Medical Device and as such it is important that all users understand the use and adjustments that this product offers. This booklet shows the range of adjustments and gives guidelines for each type of user to follow.

### Professional/Technical users

This refers to the Therapist and Prescribing Practitioner.

Ensure you read all sections in this booklet and are fully familiar with all the adjustments. As well as the selection, prescription and set up of the product to suit the client's needs, the technical user has the responsibility for the induction of the Carer, ensuring that the Carer:

- Has an understanding of the safety aspects of the product
- Is familiar with the product. What to use and what not to use
- Knows which accessories have been added and what daily adjustments to make
- Has an understanding of the care and cleaning procedures

A formal hand over procedure should be adopted for this product. Use the separate Inspection Log to record set ups and changes to the product. Jenx Limited offers Product Courses for Technical Users. Please contact us for more information.

### Carer (This section refers to the daily carer)

This product is a Prescribed Medical Device. It should only be used with the guidance of a prescribing professional. Do not make any adjustments other than those you have been instructed to make.

The Carer section of this guide gives the adjustments needed to aid daily use only, any other adjustments are only to be performed by the Therapist.

### Re-Issue (This section refers to Stores Personnel)

Stores personnel must follow the checks and maintenance guide before re-issue. The Medicines and Healthcare products Regulatory Agency (MHRA) releases regular bulletins regarding product updates and issues. These should be monitored.

- Records should be kept on all products serviced or re-issued
- Repairs or replaced parts should be traceable
- The Jenx serial number should always stay with the product and never be removed
- Instructions should always be issued with the product. Copies are available from Jenx Limited or can be downloaded from [www.jenx.com](http://www.jenx.com)
- Always inform the technical user before a product is issued to a home for set-up purposes
- If the product is to be re delivered, ensure adequate and secure packaging is used
- If in any doubt as to the safety of this product do not issue it, contact Jenx Limited for advice
- Products must only be issued fully assembled, clean and in good working order. Instruction for Use must be with the product

Jenx Limited offer Technical User Courses for stores personnel. The course gives guidance for: maintenance, inspection of the products, regulatory information, cleaning. Please contact us for more information.

# Specification & Warranty



Description	Cot (mm)	Bed (mm)
<b>Width</b>	560	900
<b>Length</b>	1200	1900
<b>Height (including base)</b>	170	170
<b>Individual cushion width (single)</b>	90	90
<b>Individual cushion width (double)</b>	190	190
<b>Individual cushion height</b>	150	150
<b>Individual cushion length</b>	560	900
<b>No of single cushions supplied</b>	8	15
<b>No of double cushions supplied</b>	2	2

## Warranty

The Instruction for Use of this product should be followed carefully. It is impossible to eliminate all risks inherently associated with the use of this product. Product failure or other unintended consequences may result because of such factors as improper storage, use or maintenance, unauthorised and inappropriate alteration or repair or improper or violent treatment, excessive strain, use of improper replacement parts, or because of normal wear and tear, all of which are beyond the control of the Manufacturer and Seller. Buyer and User assume all such risks.

Manufacturer and Seller warrant that this product will be free from defects in material and workmanship for a period of 24 months from the date of purchase and is reasonably fit for the purposes stated in the Instruction for Use, subject to the inherent risks under normal use conditions. This Warranty does not extend to the use of the product contrary to the Instruction for Use, or under abnormal conditions, or under conditions not reasonably foreseeable to or beyond the control of the Manufacturer or Seller. Buyer and User assume the risk of any such use. MANUFACTURER MAKES NO WARRANTIES OF SATISFACTORY QUALITY OR OF FITNESS FOR A PARTICULAR PURPOSE NOR ANY OTHER EXPRESS OR IMPLIED WARRANTY EXCEPT AS STATED ABOVE.

In no event shall Manufacturer or Seller be liable for any incidental, consequential or special damages resulting from the use of this product. THE EXCLUSIVE REMEDY OF THE USER OR BUYER AND THE EXCLUSIVE LIABILITY OF MANUFACTURER AND SELLER FOR ANY AND ALL CLAIMS, LOSSES, INJURIES OR DAMAGES (INCLUDING CLAIMS BASED ON BREACH OF WARRANTY, CONTRACT, NEGLIGENCE, TORT STRICT LIABILITY OR OTHERWISE) RESULTING FROM THE USE OF THIS PRODUCT, SHALL BE THE RETURN OF THE PURCHASE PRICE OF THE PRODUCT OR THE REPLACEMENT OF THE PRODUCT.

Manufacturer and Seller offer this product, and Buyer and User accept it, subject to the foregoing conditions of sale and limitations of warranty and liability, which may not be modified except by written agreement signed by a duly authorised representative of the Manufacturer.

# Assembly



1. Unroll the aluminium base carefully on top of the existing bed base or mattress.

2. Fasten the aluminium base to the bed using the anchor straps. Pass the strap through the white link\* nearest to you and thread it through the link on the opposite side of the bed. Take the strap loop around the existing bed base or mattress and fasten through the tri-glide. Pull tight. Use an anchor strap at either end of the bed for security.

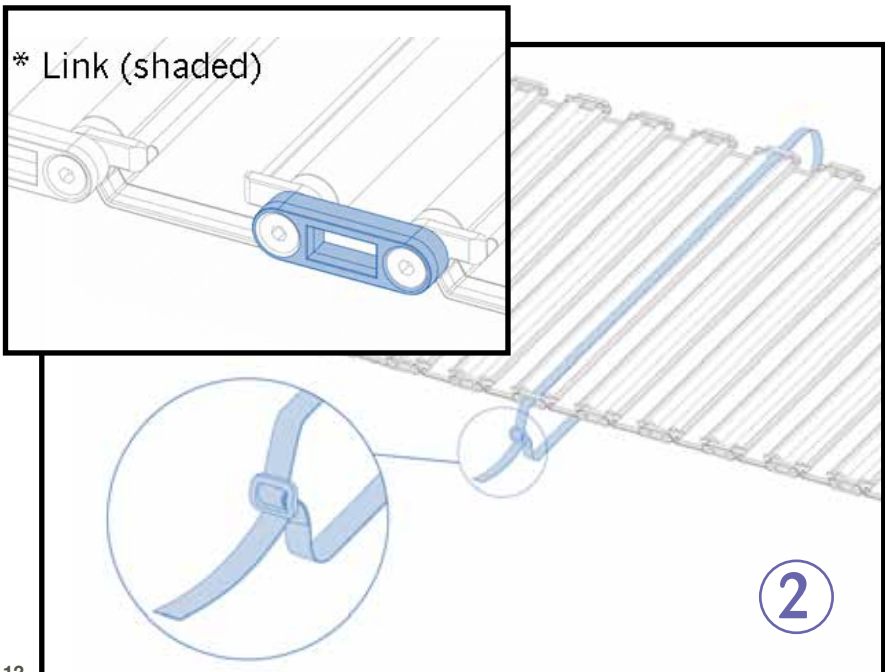

CHAPTER TWO

# Frequent Adjustments



# Mattress Units



## Inserting the mattress units



Double mattress unit



Single mattress unit

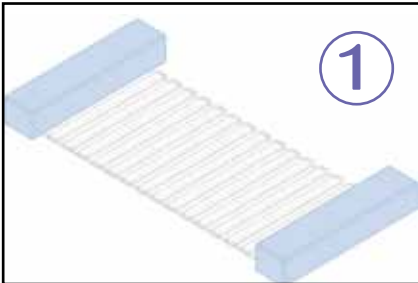

1

Double mattress unit used at each end



2

Push the plastic clip into the link at one end



3

Push the plastic clip into the link at the other end

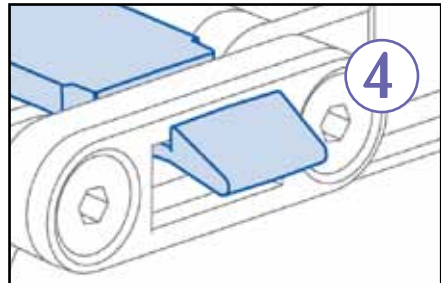

4

The image above shows the clip securely located into the link

## Removing the mattress units

To remove the mattress units, pull from the middle and lift the unit out



# Fitting & Removing Covers



Note: Wash sheets before use  
Sheets fit as shown above, in the same way as a standard fitted sheet



Note: Do not hook the cover over the clip. As shown opposite

CHAPTER THREE

# Optional Components





# Glide Lock Accessories



## Fitting the glide lock accessories



Insert the glide lock end into the aluminium base of the bed, between two of the sections of mattress, as shown above.

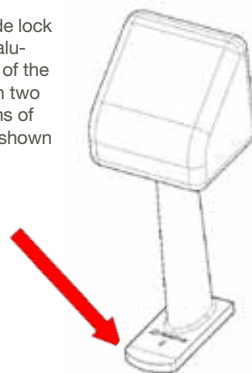

## Adjusting the glide lock accessories: Position



1: To move backwards, tip the pad forwards

2: To move forwards, tip the pad backwards

## Adjusting the glide lock accessories: Angle



To rotate the glide-lock positioning pads, hold the top of the pad, pull slightly upwards and rotate. When in desired position, push down to lock.

### Why? Benefits of the Adjustments:

The positioning pads are the main means of controlling posture in Dreama2. The pads slide between the mattress sections giving unlimited scope to support a whole body, a limb or a joint. The pads can be moved with the client in position and the client's position can be changed in moments without the need to take them out of the bed. The rotating mechanism allows you to contour the support even more closely to suit an individual client's needs. See the examples below of how the positioning pads can be used.



# Locking Stop Accessories



### Fitting the locking stops and locking stop Accessories



1. Slide Locking stops in from the end of the channel, as shown left.

2. Locking stops can also be dropped sideways into the channel and turned to locate

3. Make sure the locking foot is lying completely horizontally across the channel before tightening it up. Tighten the white wing nut to secure.

4. When using to keep an accessory in place, make sure that the straight edge of the locking foot is touching the straight edge of the accessory base.

Where the locking feet are an integral part of an accessory (except hoops) they come attached to the accessory via webbing. There are quick release buckles on the webbing. Ensure these buckles are done up when using the locking feet. Do not use the locking feet in the same channel as the accessory if you want to use the quick release mechanism.

#### Why? Benefits of the Adjustments:

Locking Feet/Pad Stops are used to enhance the security of the accessory's position when the client displays repetitive movements that are likely to 'walk' the accessory out of place. As locking feet, the locking section comes as part of the accessory.

The locking section can be used on its own to form a stop in a given channel which ensures that accessories such as support pads are always positioned in the same place. This allows the technical user to set up positions for pads and accessories and carers simply push the pads up to the stops when using Dreama2.

# Accessories



## Positioning Pads



The positioning pads are glide lock accessory and are fitted as described on page 17. They can also be used along with locking feet, as shown on page 18

### Why? Benefits of the Adjustments:

Positioning pads are used to hold the client in the required position

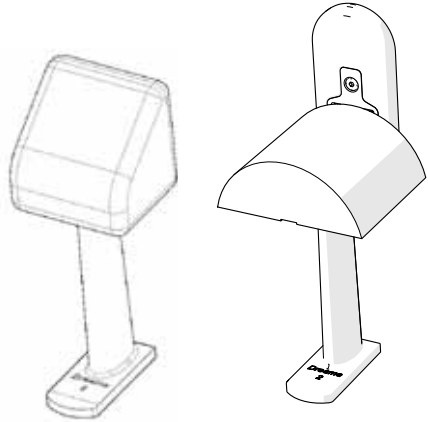

## Abduction Block



The abduction block is a glide lock accessory and is fitted as described on page 17. It can also be used along with locking feet, as shown on page 18

### WHY?

The abduction block is used to maintain the client's legs in abduction.



## Leg Supports

The Leg Supports are glide lock Accessories and are fitted as described on page 17. They can also be used along with locking feet, as shown on page 18.

To position a client in the leg supports, undo the buckle on the side of the knee cup, open the knee cup, gently lift the client's leg into position. Once in position, clip the buckle back together, ensuring at least a fingers width between the client's knee and the upper pad.

### WHY?

The leg supports are designed for use when there is a specific reason that the leg requires extra support. This may be following injury or surgery.



# Accessories



## Footplates (angle adjustable)



The angle adjustable foot supports use the glide-lock post and rotating head system, as explained on page 17. They can be used in conjunction with locking feet as explained on page 18.

### WHY?

The foot support allows the correct therapeutic position for the feet to be achieved and offers support for the feet in the chosen position.



To alter the footplate angle, loosen the wing knob as shown, adjust angle and tighten the wingknob



To alter the footplate position, loosen the two wing knobs shown, slide forwards or backwards and retighten both wingknobs

## Hoops



The hoops use the locking stop attachment and fit as shown on page 18.

### Why? Benefits of the Adjustments:

Hoops can control a client's movements while still allowing them some 'wriggle room'. In this way a given range of movement can be prescribed.

Hoops can also be used to take the weight of bed covers so protecting clients who cannot tolerate the weight or those who have broken skin.



Do not use hoops over clients head or neck

# Accessories



## Side Lying Platform: Fitting



Step 1: Insert four positioning pads as shown opposite, these will form the base for the side lying platform



Step 2: Position the side lying leg platform on top of the pads. There is a webbing strap with a locking foot on each corner of the board. Secure the locking feet then tighten the webbing by pulling upwards on the strap.

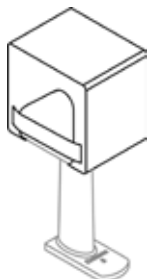

A spacer block is available (shown left) to provide a height between a small and medium pad. To use, simply insert the small pad into the hole so it fits snugly and do up the Velcro.

## Side Lying Platform: Pad Adjustment



The positioning pads on top of the platform are used to support the upper leg. These pads can be moved anywhere along the surface of the board or alternatively, removed altogether.



To alter their position, loosen the buckle located under the board and move the pads up or down, depending on the position desired. Once you have the pads in position, tighten the buckle.

You can also alter the width between the pads by moving them along the webbing strap. To do this, undo the cam lock, move the pads to the desired position and close the cam lock against the pad.



# Accessories



## T-Roll (height adjustable)

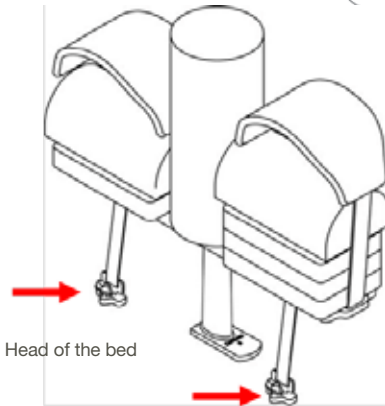
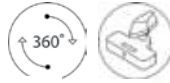

Head of the bed

Locking feet are attached to the T-Roll with snap buckles.



Use the snap buckles on the side to secure the client's leg to the T-Roll.

You can lengthen the straps to give the client more room.



The pommel can be removed by twisting anti-clockwise and lifting out.



To replace the central pommel, push into the slot on the base and twist clockwise. Check it is secure.

# Accessories



The height of the horizontal supports can be individually altered. You can use 0, 1, 2 or 3 foam blocks on each side.



1  
Unclip buckle



2  
Loosen strap



3



4

Push the side post as shown to remove the foam blocks



5

Remove or replace foam blocks as required



6

Re insert the side post



7

Secure the strap through the tri-glide and snap buckles, making sure the base and side support are secured.



8

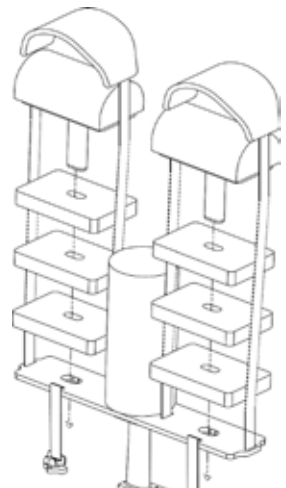

CHAPTER FOUR

# Maintenance & Inspection





# Maintenance & Inspection



Each Jenx product must be checked and inspected in line with the advice given in this IFU. Failure to complete these regular checks poses a risk to the user. Every year, each product must be thoroughly inspected by a person competent to assess faults and able to rectify or out source rectification. The maximum period that should elapse between full product inspections is 1 year. After 3 years or from purchase where a product is subject to heavy use, this should be increased to six monthly full inspections. For complete peace of mind, Jenx Limited offers Product Inspections. Charges apply

Jenx Limited products are usually assessed for an individual client, therefore the following points must be adhered to prior to the re-issuing of any Jenx products.

- Check with issuing Therapist that the product is standard and no special attachments or modifications have been made. If modifications have been made: contact Jenx Limited for advice
- Check that the product has been fully cleaned, taking into account the condition of the fabric and the foam inside
- Check that all hand wheels and levers are in good condition and fitted securely
- Check the product and any accessories fully for any sign of wear and tear or distortion
- Check that all the functions of the product are working correctly e.g. tilt, height adjustment or back recline, etc.
- Always ensure that the Instruction For Use stays with the product and is passed on to the new user. For new sets of instructions please contact our Sales Support Department on 0114 285 3376 or visit [www.jenx.com](http://www.jenx.com)
- If the product is being delivered, always ensure that the product is packed securely
- We strongly recommend that all straps and harnesses are replaced with new ones before re-issue. Only genuine Jenx parts should be fitted
- Check that gas spring levers are not bent. Do not use the product if any levers are bent. Contact Jenx Limited to arrange replacement
- Check that the product to be re-issued is to the correct specification for the intended new user. Each user may require different ranges of accessories

Follow the product log book document, supplied separately.

Use extra pages if required, extra sheets are available from the Jenx Limited website: [www.jenx.com](http://www.jenx.com)

# Maintenance & Inspection



Stores should follow the MHRA guidelines for the recording, issuing, servicing or repairing of products in their charge. Check the MHRA web site for the latest bulletins:  
[www.mhra.gov.uk](http://www.mhra.gov.uk)

- **Structure** Is the product structurally sound, no wobbles or loose parts?
- **Safety** Is the product safe and fit for use?
- **Straps** Are the straps in good condition and not showing any signs or wear? Check straps for fraying and missing or broken buckles, ensure all webbing end clips are in place.
- **Stability** Is the product stable on an even surface, no rocking?
- **Screws, Nuts and Bolts** Are there nuts and bolts missing or damaged?
- **Castors** Are the castors in good order? Do swivels and brakes work?
- **Springs** Do all gas springs work and hold pressure and weight?
- **Sandals** Are the sandals in good condition? Do straps and Velcro show signs of wear?
- **Upholstery and PU** Is the upholstery and PU in good, clean condition with no rips, wear or gaping of the cushions?
- **Steel and Woodwork** Is the steel and wood work in good order? Check for deformities, splinters or breaks

If there is any doubt about the safety of the product, do not hesitate to contact our Customer Support Department for advice

Products should be thoroughly decontaminated in line with MHRA and local guidelines prior to inspection, storage and re-issue

Jenx Limited can take no responsibility for re-issue of products

# Frequently Asked Questions



**Question:** Who is a qualified person to inspect products?

**Answer:** The purchasing authority has a duty under the MHRA guidelines DB2006 (05) to address training for Medical Devices Management. Check with your authority.







**Question:** Does Jenx run technical competency courses?

**Answer:** Yes. Please visit [jenx.com](http://jenx.com) for details of available courses.

**Question:** Why does my tilt-in-space lever not work?

**Answer:** If your lever does not operate properly, ensure that it is fully unlocked and try again. Do not use excessive force

## Notes

-  Seating
-  Standing
-  Sleeping
-  Therapy
-  Mobility
-  Bathroom